

Unionwell

■ Dimensions and Operating Characteristics of Basic Shape

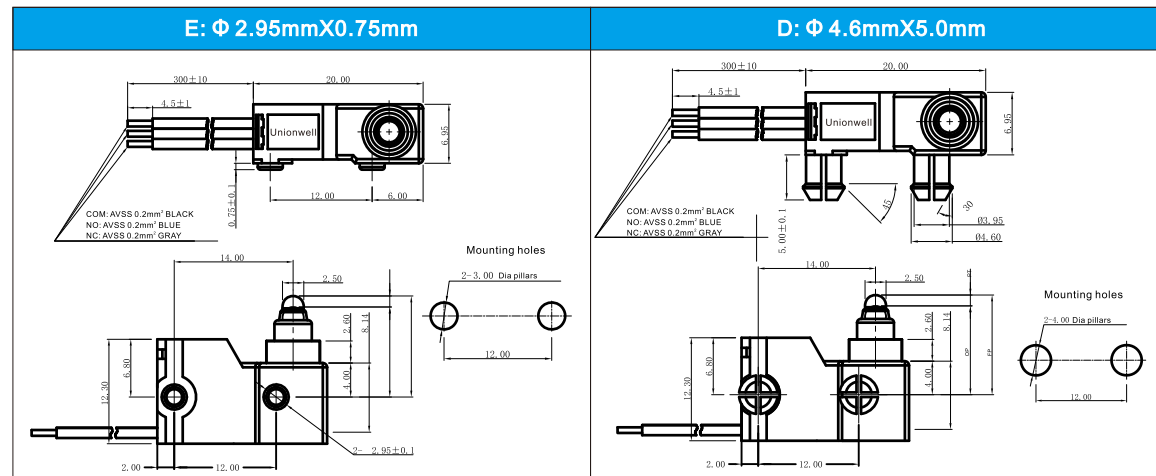

■ Switch Lever and Operating Characteristics

◆ G305-130F00A34D-IFU

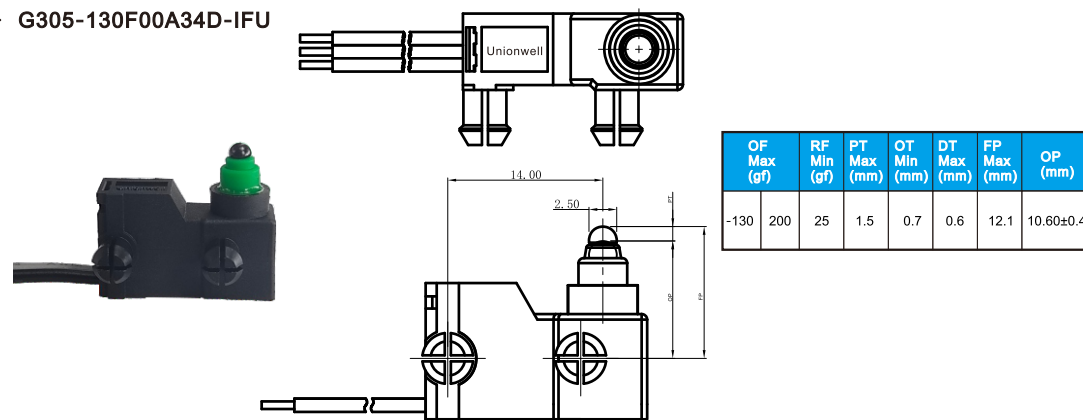

◆ G305-130F13A34D-IFU

